

PD 109

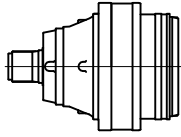

	i	T ₂ [Nm]				n _{1max} [min ⁻¹]	T _{2max} [Nm]	P _t [kW]
		n _{2xh}						
		10 000	20 000	50 000	100 000			
PD 109 S1	3.66	7930	7020	5970	5290	2800	14040	30
	4.42	7240	6410	5450	4830	2800	12820	30
	5.00	6360	5630	4790	4240	2800	11260	30
	5.80	5380	4760	4050	3590	2800	9520	30
	7.00	4350	3850	3280	2900	2800	7700	30
PD 109 S2	13.8	7930	7020	5970	5290	2800	14020	18
	18.2	7240	6410	5450	4830	2800	12820	18
	20.6	6360	5630	4790	4240	2800	11260	18
	22.8	7240	6410	5450	4830	2800	12820	18
	26.5	7240	6410	5450	4830	2800	12820	18
	30.0	6360	5630	4790	4240	2800	11260	18
	36.2	6360	5630	4790	4240	2800	11260	18
	42.0	5380	4760	4050	3590	2800	9520	18
PD 109 S3	50.7	4350	3850	3280	2900	2800	7700	18
	53.7	7930	7020	5970	5290	2800	14040	14
	64.8	7930	7020	5970	5290	2800	14040	14
	71.6	7240	6410	5450	4830	2800	12820	14
	78.2	7240	6410	5450	4830	2800	12820	14
	88.3	6360	5630	4790	4240	2800	11260	14
	93.6	7240	6410	5450	4830	2800	12820	14
	102.1	7930	7020	5970	5290	2800	14040	14
	112.9	7240	6410	5450	4830	2800	12820	14
	127.8	7930	7020	5970	5290	2800	14040	14
	139.2	6360	5630	4790	4240	2800	11260	14
	148.7	7240	6410	5450	4830	2800	12820	14
	155.3	6360	5630	4790	4240	2800	11260	14
	174.3	6360	5630	4790	4240	2800	11260	14
	194.8	5380	4760	4050	3590	2800	9520	14
	216.7	7240	6410	5450	4830	2800	12820	14
244.6	6360	5630	4790	4240	2800	11260	14	
283.8	5380	4760	4050	3590	2800	9520	14	
342.5	4350	3850	3280	2900	2800	7700	14	
PD 109 S4	301.1	7930	7020	5970	5290	2800	14040	8
	332.4	7930	7020	5970	5290	2800	14040	8
	347.9	7930	7020	5970	5290	2800	14040	8
	400.6	7930	7020	5970	5290	2800	14400	8
	434.3	7930	7020	5970	5290	2800	14400	8
	474.3	7930	7020	5970	5290	2800	14400	8
	523.5	7930	7020	5970	5290	2800	14400	8
	571.7	7930	7020	5970	5290	2800	14400	8
	632.7	7240	6410	5450	4830	2800	12820	8
	661.8	7240	6410	5450	4830	2800	12820	8
	747.3	6360	5630	4790	4240	2800	11260	8
	768.6	7240	6410	5450	4830	2800	12820	8
	832.3	7240	6410	5450	4830	2800	12820	8
	869.9	6360	5630	4790	4240	2800	11260	8
	976.4	6360	5630	4790	4240	2800	11260	8
	1048.6	6360	5630	4790	4240	2800	11260	8
	1177.0	6360	5630	4790	4240	2800	11260	8
	1366.8	6360	5630	4790	4240	2800	11260	8
1651.4	6360	5630	4790	4240	2800	11260	8	
2968.8	4350	3850	3280	2900	2800	7700	8	

PDA 109

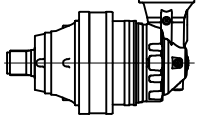

	i	T ₂ [Nm]				n _{1max} [min ⁻¹]	T _{2max} [Nm]	P _t [kW]
		n _{2xh}						
		10 000	20 000	50 000	100 000			
PDA 109 S2	12.6	7930	7020	5970	5290	2800	14040	18
	15.2	7240	6410	5450	4830	2800	12820	18
	17.2	6360	5630	4790	4240	2800	11260	18
	20.0	5380	4760	4050	3590	2800	9520	18
	24.1	7240	6410	5450	4830	2800	12820	18
	27.2	6360	5630	4790	4240	2800	11260	18
	31.5	5380	4760	4050	3590	2800	9520	18
	38.1	4350	3850	3280	2900	2800	7700	18
PDA 109 S3	53.8	7240	6410	5450	4830	2800	12820	14
	55.5	7240	6410	5450	4830	2800	12820	14
	60.4	6360	5630	4790	4240	2800	11260	14
	67.1	7240	6410	5450	4830	2800	12820	14
	77.9	7240	6410	5450	4830	2800	12820	14
	87.9	6360	5630	4790	4240	2800	11260	14
	94.1	7240	6410	5450	4830	2800	12820	14
	106.3	6360	5630	4790	4240	2800	11260	14
PDA 109 S4	123.3	5380	4760	4050	3590	2800	9520	14
	148.8	4350	3850	3280	2900	2800	7700	14
	157.7	7930	7020	5970	5290	2800	14040	8
	174.1	7930	7020	5970	5290	2800	14040	8
	190.1	7930	7020	5970	5290	2800	14040	8
	210.3	7240	6410	5450	4830	2800	12820	8
	229.6	7240	6410	5450	4830	2800	12820	8
	248.4	7930	7020	5970	5290	2800	14040	8
	274.8	7240	6410	5450	4830	2800	12820	8
	300.7	7240	6410	5450	4830	2800	12820	8
	331.2	7240	6410	5450	4830	2800	12820	8
	361.6	7240	6410	5450	4830	2800	12820	8
	393.0	5380	4760	4050	3590	2800	9520	8
	453.0	7240	6410	5450	4830	2800	12820	8
	511.4	6360	5630	4790	4240	2800	11260	8
	557.0	5380	4760	4050	3590	2800	9520	8
593.9	6360	5630	4790	4240	2800	11260	8	
656.7	6360	5630	4790	4240	2800	11260	8	
717.7	6360	5630	4790	4240	2800	11260	8	
832.5	5380	4760	4050	3590	2800	9520	8	
921.5	6360	5630	4790	4240	2800	11260	8	
1068.9	5380	4760	4050	3590	2800	11260	8	

PD/PDA 109

HS

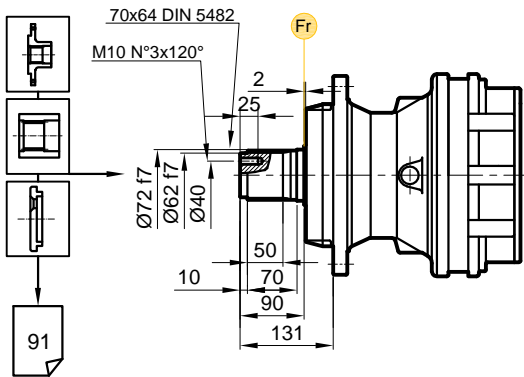

HC

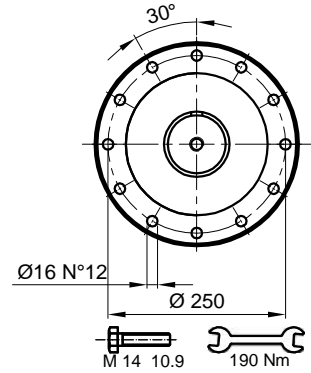
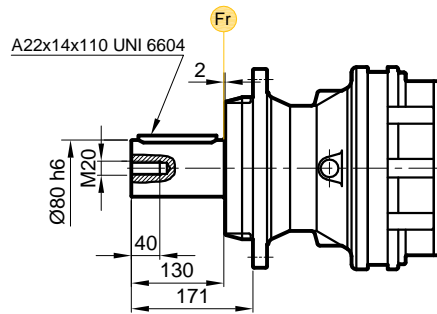

PD..

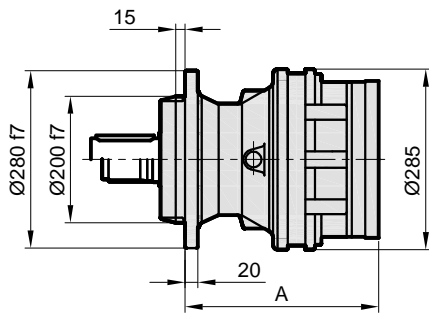

PDA..

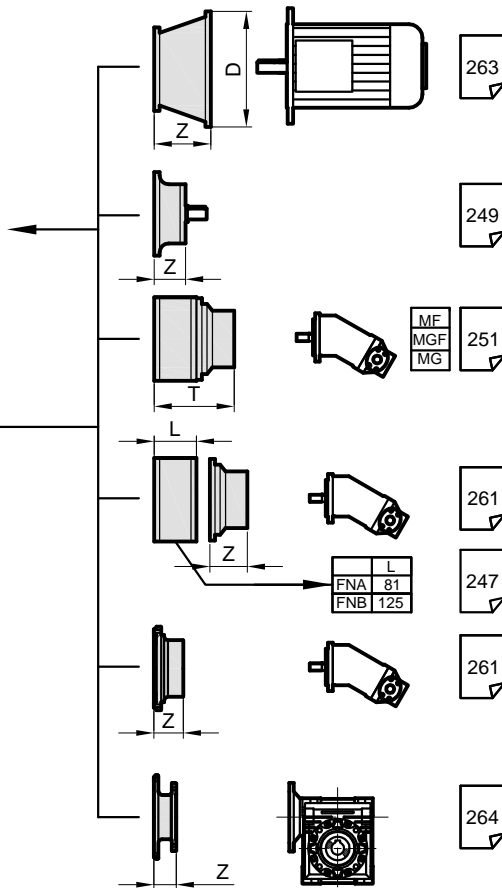
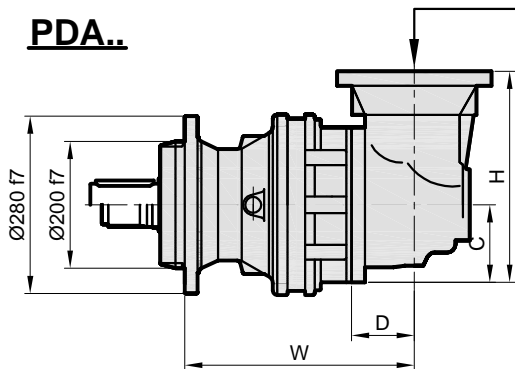

Stage	W	D	C	H	A	PD H	PDA H
S1	-	-	-	-	251	67	-
S2	339	88	140	380	310	79	104
S3	385	75	93	252	358	85	94
S4	433	75	93	252	406	91	100

	H71		H80-90		H100		H132		H160-180		H200		H225		H250-280	
Stage	D	Z	D	Z	D	Z	D	Z	D	Z	D	Z	D	Z	D	Z
S1	-	-	-	-	-	-	-	-	350	120	400	148	450	148	550	183
S2	185	32	200	60	250	71	300	104	350	120	400	148	450	148	-	-
S3	185	32	200	60	250	71	300	104	350	120	-	-	-	-	-	-
S4	185	32	200	60	250	71	300	104	350	120	-	-	-	-	-	-

PD/PDA 109

SF

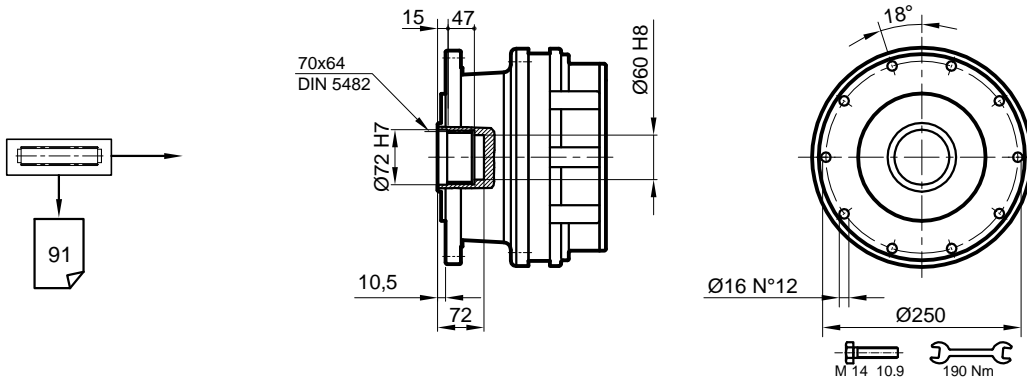

PD..

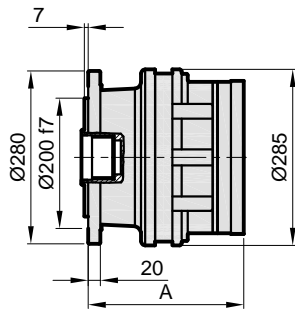

PDA..

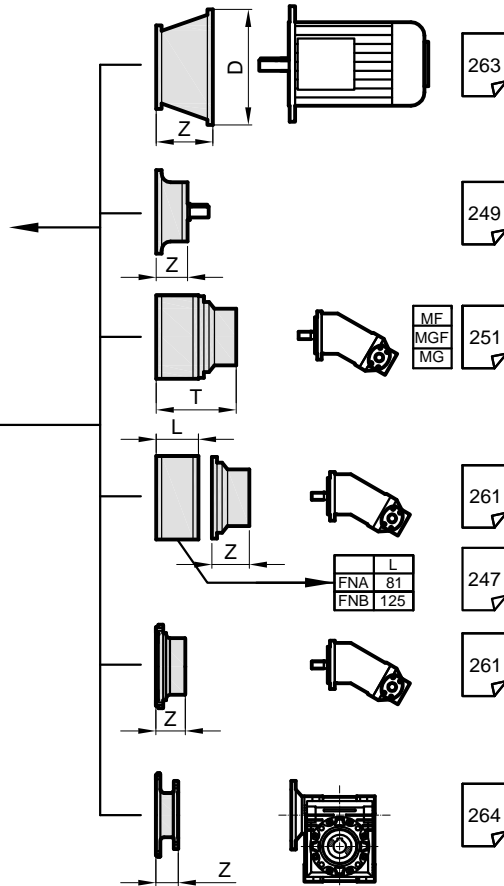
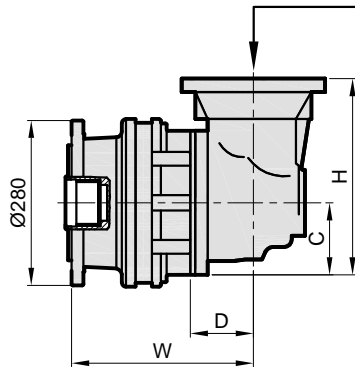

Stage	A	D	C	H	W	PD SF	PDA SF
S1	197	-	-	-	-	49	-
S2	257	88	140	380	285	61	86
S3	305	75	93	252	332	67	76
S4	353	75	93	252	380	73	82

	H71		H80-90		H100		H132		H160-180		H200		H225		H250-280	
Stage	D	Z	D	Z	D	Z	D	Z	D	Z	D	Z	D	Z	D	Z
S1	-	-	-	-	-	-	-	-	350	120	400	148	450	148	550	183
S2	185	32	200	60	250	71	300	104	350	120	400	148	450	148	-	-
S3	185	32	200	60	250	71	300	104	350	120	-	-	-	-	-	-
S4	185	32	200	60	250	71	300	104	350	120	-	-	-	-	-	-

PD/PDA 109

SDF

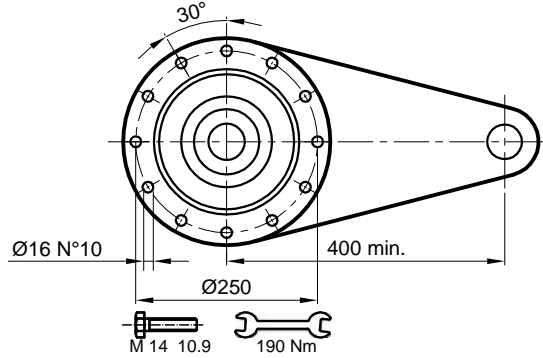
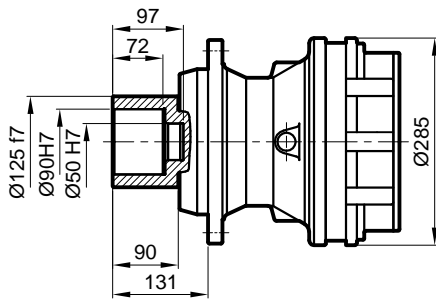
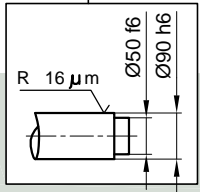
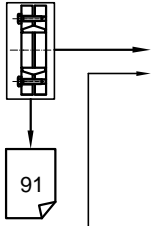

$M_{max} = 13 \text{ kNm}$

Belirtilen maksimum tork sadece PDS tarafından verilen sıkma bileziği ile mümkündür.
The maximum torque indicated is valid only with shrink discs supplied by PDS.
Das dargestellte, maximale Drehmoment gilt nur mit von PDS.

PD..

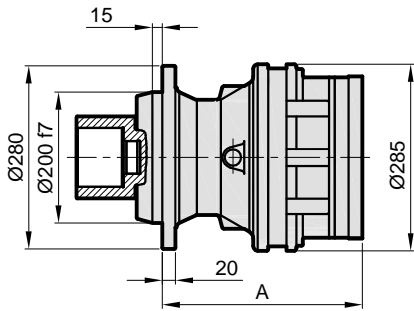

PDA..

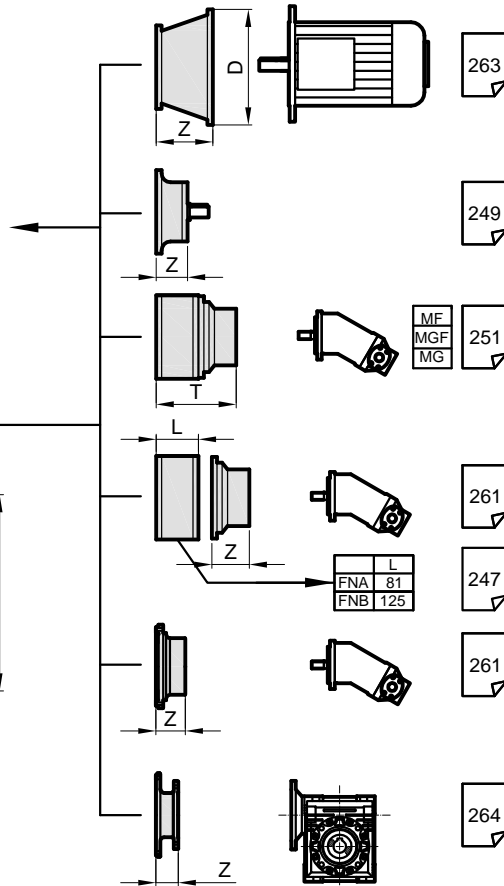
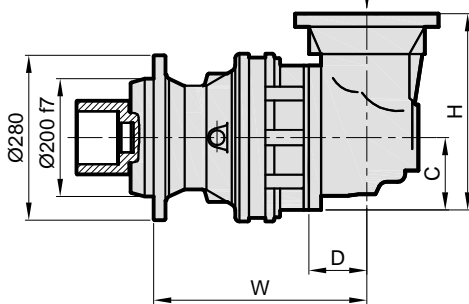

Stage	W	D	C	H	A	PD		PDA	
						SDF	SDF	SDF	SDF
S1	-	-	-	-	251	70	-	-	
S2	339	88	140	380	310	82	107		
S3	385	75	93	252	358	88	97		
S4	433	75	93	252	406	94	103		

	H71		H80-90		H100		H132		H160-180		H200		H225		H250-280	
Stage	D	Z	D	Z	D	Z	D	Z	D	Z	D	Z	D	Z	D	Z
S1	-	-	-	-	-	-	-	-	350	120	400	148	450	148	550	183
S2	185	32	200	60	250	71	300	104	350	120	400	148	450	148	-	-
S3	185	32	200	60	250	71	300	104	350	120	-	-	-	-	-	-
S4	185	32	200	60	250	71	300	104	350	120	-	-	-	-	-	-

PD/PDA 109

DKM

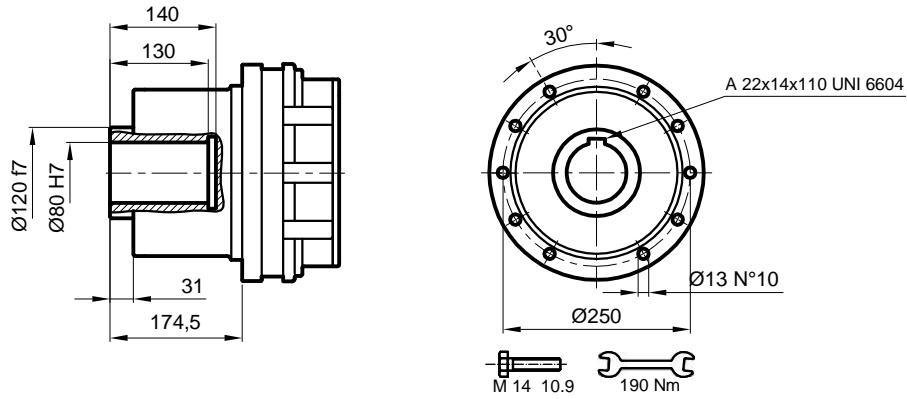

PD..

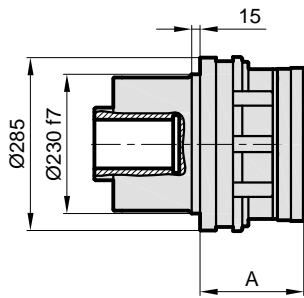

PDA..

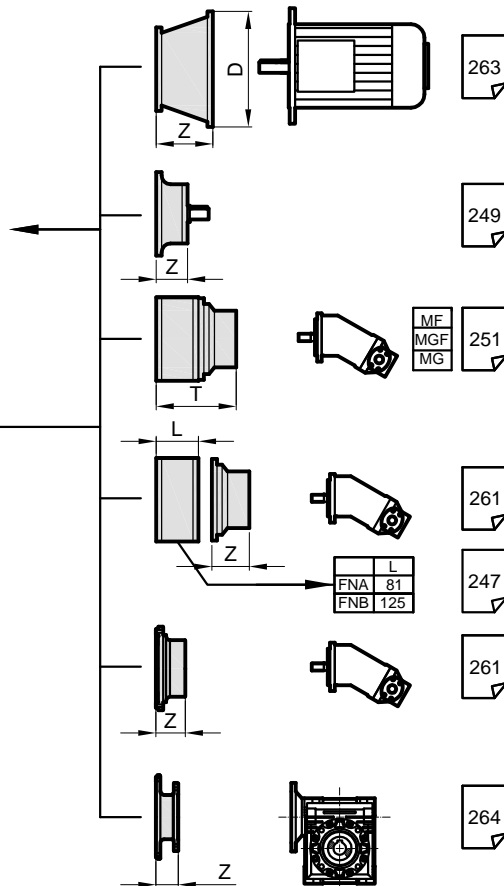
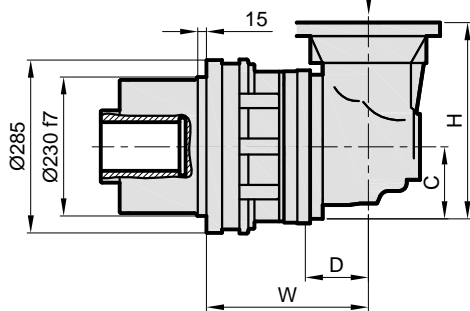

Stage	W	D	C	H	A	PD		PDA	
						SDF	DF	SDF	DF
S1	-	-	-	-	218	70	-	-	
S2	307	88	140	380	277	82	107	-	
S3	352	75	93	252	325	88	97	-	
S4	400	75	93	252	373	94	103	-	

	H71		H80-90		H100		H132		H160-180		H200		H225		H250-280	
Stage	D	Z	D	Z	D	Z	D	Z	D	Z	D	Z	D	Z	D	Z
S1	-	-	-	-	-	-	-	-	350	120	400	148	450	148	550	183
S2	185	32	200	60	250	71	300	104	350	120	400	148	450	148	-	-
S3	185	32	200	60	250	71	300	104	350	120	-	-	-	-	-	-
S4	185	32	200	60	250	71	300	104	350	120	-	-	-	-	-	-

PD/PDA 109

FVS

FVC

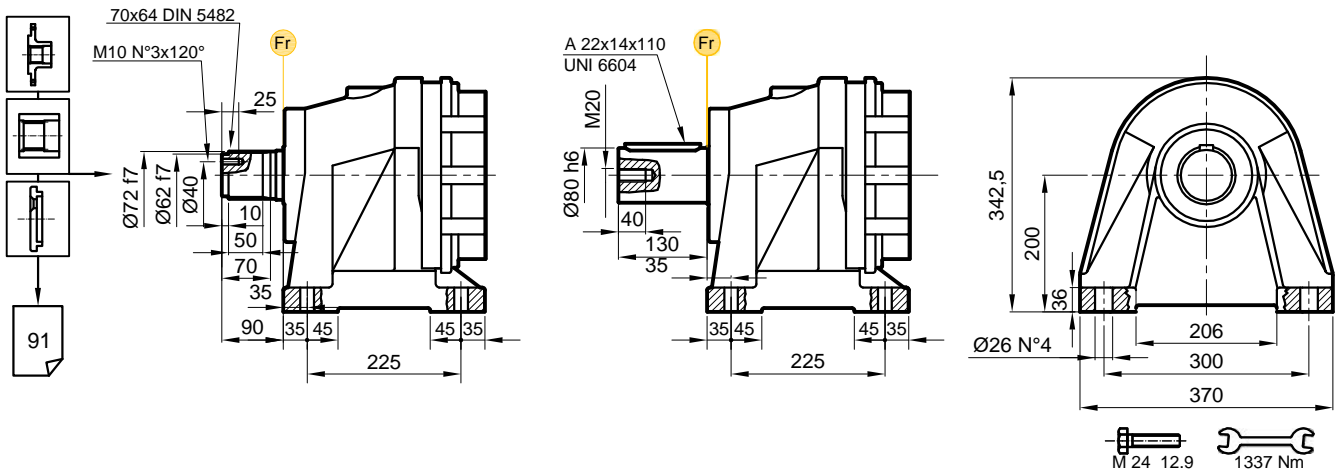

PD..

PDA..

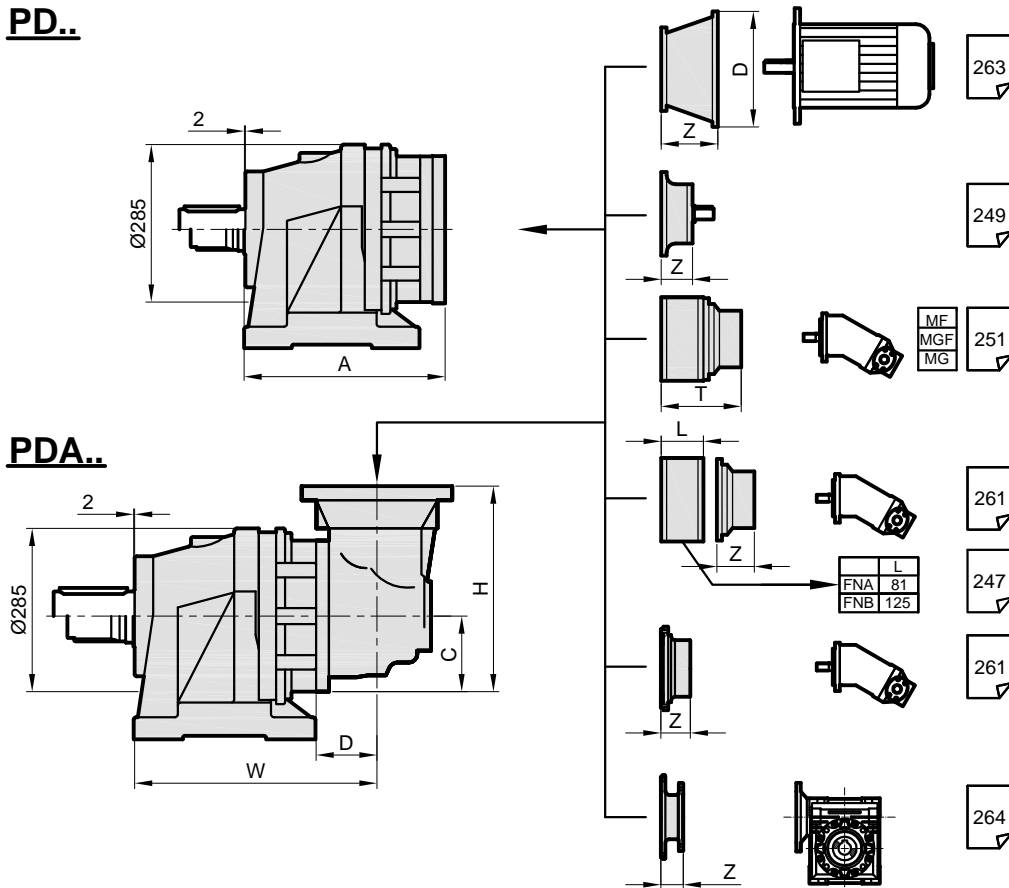

Stage	W	D	C	H	A	PD FVC	PDA FVC
S1	-	-	-	-	292	83	-
S2	380	88	140	380	351	95	120
S3	426	75	93	252	400	101	110
S4	475	75	93	252	447	107	116

	H71		H80-90		H100		H132		H160-180		H200		H225		H250-280	
Stage	D	Z	D	Z	D	Z	D	Z	D	Z	D	Z	D	Z	D	Z
S1	-	-	-	-	-	-	-	-	350	120	400	148	450	148	550	183
S2	185	32	200	60	250	71	300	104	350	120	400	148	450	148	-	-
S3	185	32	200	60	250	71	300	104	350	120	-	-	-	-	-	-
S4	185	32	200	60	250	71	300	104	350	120	-	-	-	-	-	-

PD/PDA 109

P Pinyon / Pinion / Ritzel

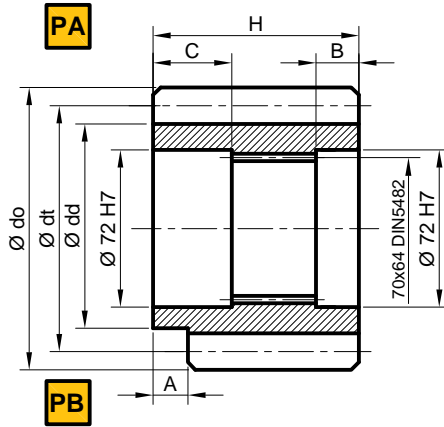

	m	z	x	dd	dt	do	H	A	B	C	Malzeme / Material / Material	Kod / Code / Bestell
PA	10	11	1,21	72,9	110	142,1	90	0	10	31	18NiCrMo5	1501.109.001
PB	10	11	1,21	72,9	110	142,1	90	9	18,5	31	18NiCrMo5	1502.109.001
PA	10	12	0	95	120	140	90	0	10	31	38NiCrMo4	1501.109.002
PA	10	13	0	95	120	155	90	0	10	30	38NiCrMo4	1501.109.003

FL Flan / Flange / Flansch

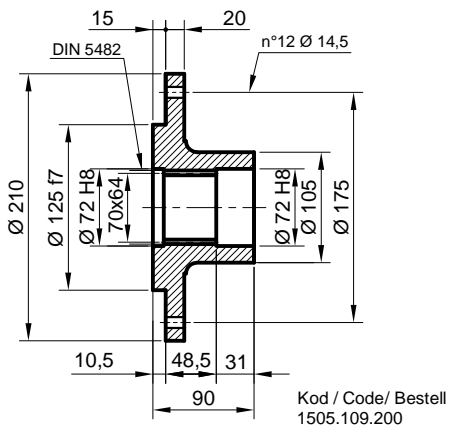

Kod / Code / Bestell
1505.109.200

FK Frezeli Kaplin / Spined bushing Innenverzahnte Buchse

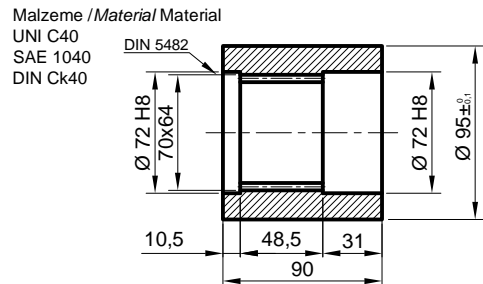

Kod / Code / Bestell
1503.109.100

SP Sabitleme Pulu / Stop bottom plate / Endscheibe

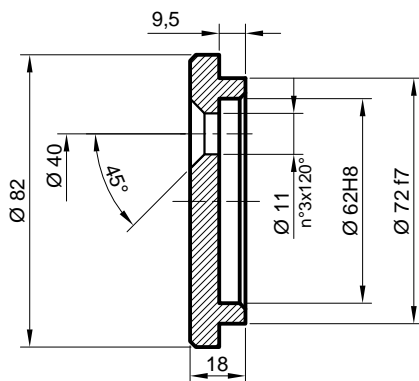

Kod / Code / Bestell
1507.109.250

SB Sıkma Bilezi i / Shrink disc Schrumpfscheibe

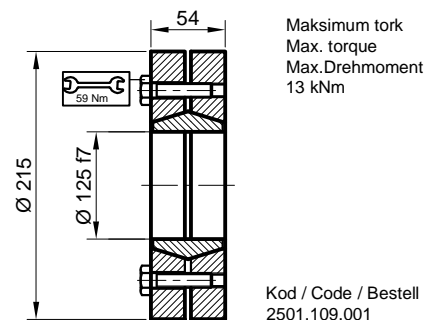

Kod / Code / Bestell
2501.109.001

FM Frezeli Mil / Splined rod Außenverzahnte Welle

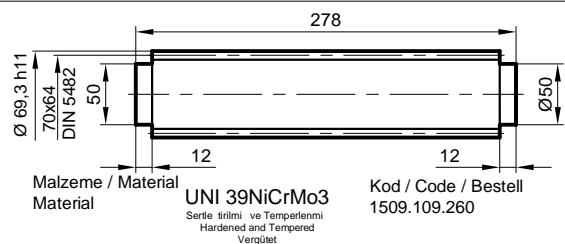

Kod / Code / Bestell
1509.109.260

PD/PDA 109

RADYAL YÜK(Fr)

A a ıdaki diyagramlar radyal yükleri ve k faktörlerini arzu edilen $n_2 \times h$ de erlerinde verir.

RADIAL LOADS(Fr)

The following curves show the radial loads and the K factors to obtain the required $n_2 \times h$ value.

RADIALLAST (Fr)

In den nachstehenden Diagrammen ist die Radiallast und der Koeffizient K dargestellt und kann mit dem gewünschten Wert $n_2 \times h$ verglichen werden.

H-FV

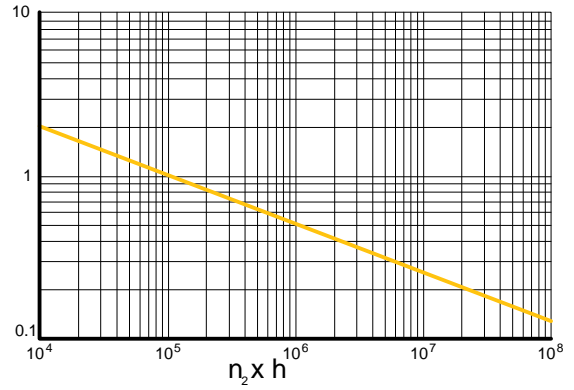
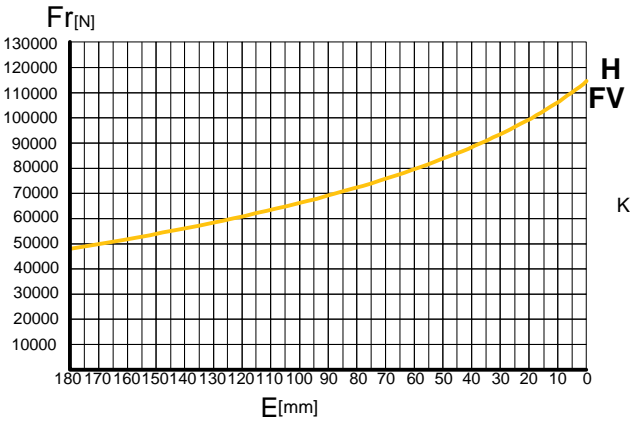

	$n \times h$				
	10^5	10^4	10^6	10^7	10^8
F	Fr		Fr . K		
FV	Fr . 0,75		Fr . K . 0,75		

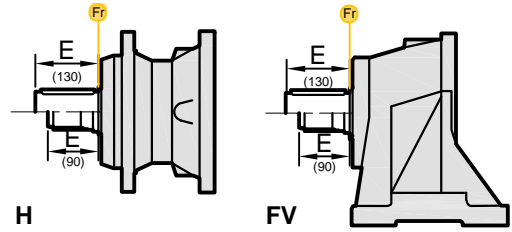

AKS YEL YÜKLER (Fa)

Tablodaki aksiyel yük de erleri çıkı tipi ve tatbik edilen yük yönünde verilmi tir.

AXIAL LOADS (Fa)

The values of the axial loads in the table refer to the output versions and load directions of application.

AXIALLAST (Fa)

Die dargestellten Werte der Axiallast basieren auf der Version und der applizierten Lastrichtung.

Fa [N]	H	FV	← →
	40000	40000	
60000	60000	60000	

